

Note:  
TPS-28 should be connected to the Aircraft regulated power buss.

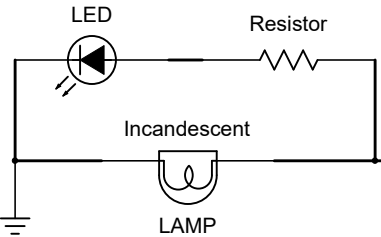
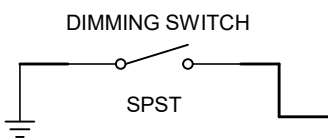
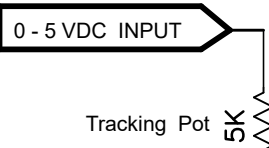
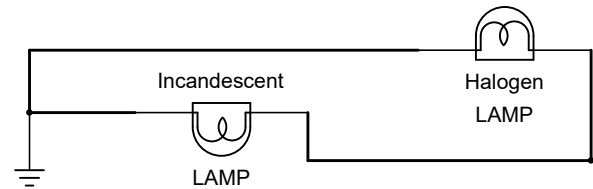

- NOTES:
1. Tracking Current 0.01 Amps Max.
  2. Max. circuit breaker size 15 Amps.
  3. Signal ground is used for adjustable resistor return.
  4. Dimmer switch will work in any mode of operation.
  5. Max. wire size is 18 GA for crimp pins.
  6. DO NOT exceed 4 Amps. per Pin IN / OUT
  7. Most LED's need Current limiting resistors, common values are 470 Ohms for 5 volts, 1K for 12 volts, 2.7K for 28 volts this gives 10ma of current for that LED.
  8. Case of TPS-28 should be connected to ground.

Executive Engineering  
www.Exec-Eng.com

|   |                    |       |  |
|---|--------------------|-------|--|
| Title TRACKING-TRIMMER for Panel Tracking |                    |       |  |
| Size A                                    | Number Track-Trim1 | Rev 1 |  |
| Date 2/20/2020                            | Drawn by EE        |       |  |
| Filename track-trim1.sch                  | Sheet 1 of 1       |       |  |

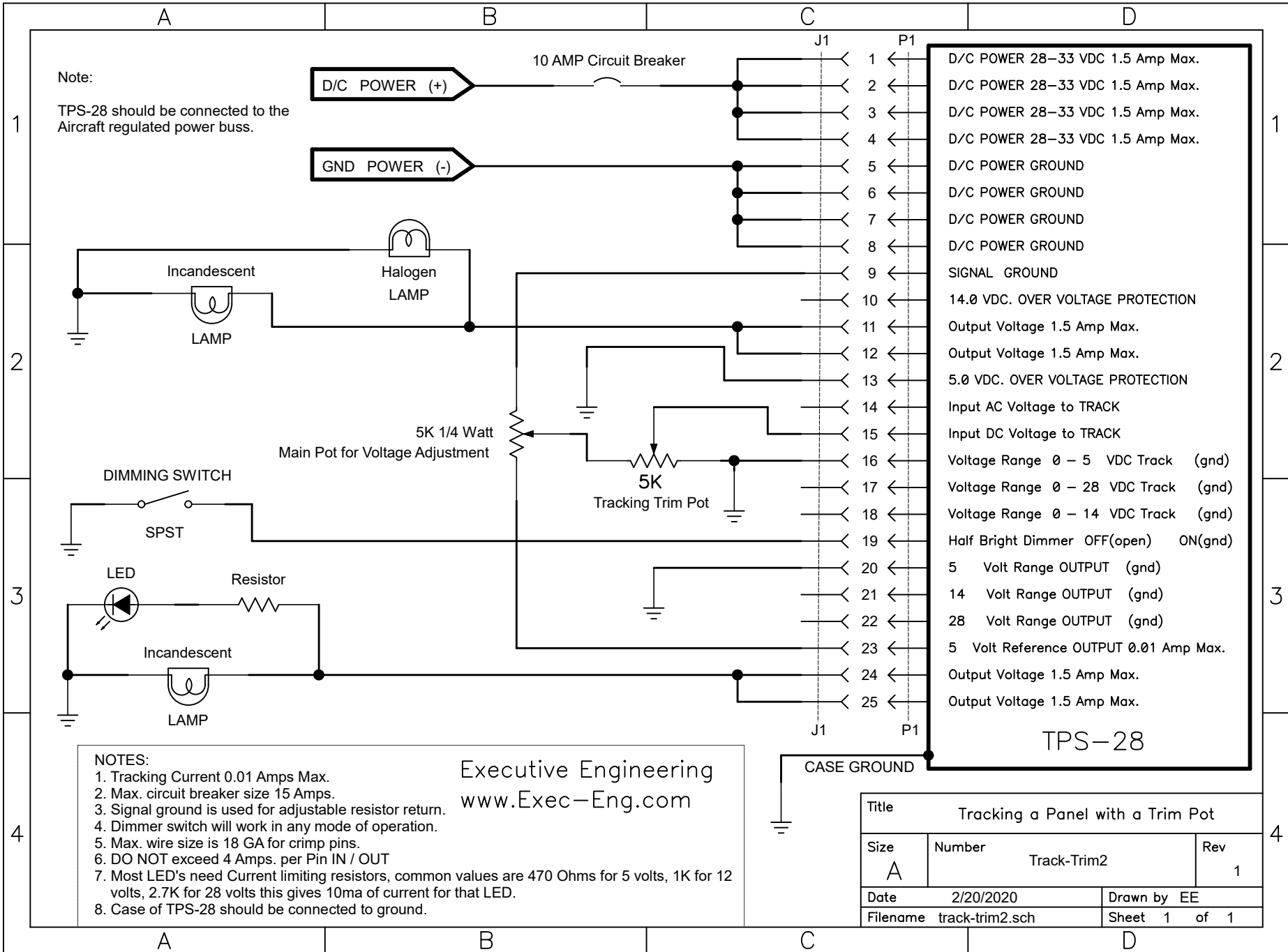

Note:  
TPS-28 should be connected to the Aircraft regulated power buss.

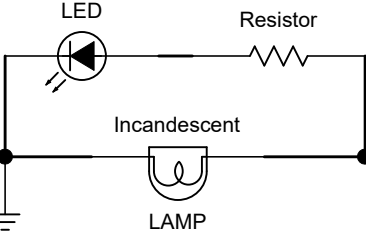
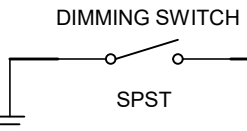
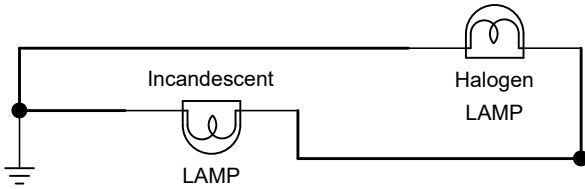

NOTES:  
 1. Tracking Current 0.01 Amps Max.  
 2. Max. circuit breaker size 15 Amps.  
 3. Signal ground is used for adjustable resistor return.  
 4. Dimmer switch will work in any mode of operation.  
 5. Max. wire size is 18 GA for crimp pins.  
 6. DO NOT exceed 4 Amps. per Pin IN / OUT  
 7. Most LED's need Current limiting resistors, common values are 470 Ohms for 5 volts, 1K for 12 volts, 2.7K for 28 volts this gives 10ma of current for that LED.  
 8. Case of TPS-28 should be connected to ground.

Executive Engineering  
www.Exec-Eng.com

|    |   |                                       |
|----|---|---------------------------------------|
| 1  | ← | D/C POWER 28-33 VDC 1.5 Amp Max.      |
| 2  | ← | D/C POWER 28-33 VDC 1.5 Amp Max.      |
| 3  | ← | D/C POWER 28-33 VDC 1.5 Amp Max.      |
| 4  | ← | D/C POWER 28-33 VDC 1.5 Amp Max.      |
| 5  | ← | D/C POWER GROUND                      |
| 6  | ← | D/C POWER GROUND                      |
| 7  | ← | D/C POWER GROUND                      |
| 8  | ← | D/C POWER GROUND                      |
| 9  | ← | SIGNAL GROUND                         |
| 10 | ← | 14.0 VDC. OVER VOLTAGE PROTECTION     |
| 11 | ← | Output Voltage 1.5 Amp Max.           |
| 12 | ← | Output Voltage 1.5 Amp Max.           |
| 13 | ← | 5.0 VDC. OVER VOLTAGE PROTECTION      |
| 14 | ← | Input AC Voltage to TRACK             |
| 15 | ← | Input DC Voltage to TRACK             |
| 16 | ← | Voltage Range 0 - 5 VDC Track (gnd)   |
| 17 | ← | Voltage Range 0 - 28 VDC Track (gnd)  |
| 18 | ← | Voltage Range 0 - 14 VDC Track (gnd)  |
| 19 | ← | Half Bright Dimmer OFF(open) ON(gnd)  |
| 20 | ← | 5 Volt Range OUTPUT (gnd)             |
| 21 | ← | 14 Volt Range OUTPUT (gnd)            |
| 22 | ← | 28 Volt Range OUTPUT (gnd)            |
| 23 | ← | 5 Volt Reference OUTPUT 0.01 Amp Max. |
| 24 | ← | Output Voltage 1.5 Amp Max.           |
| 25 | ← | Output Voltage 1.5 Amp Max.           |

|          |                 |  |  |                                  |  |     |  |
|----------|-----------------|--|--|----------------------------------|--|-----|--|
| Title    |                 |  |  | Tracking a Panel with a Trim Pot |  |     |  |
| Size     | Number          |  |  | Track-Trim2                      |  | Rev |  |
| A        |                 |  |  |                                  |  | 1   |  |
| Date     | 2/20/2020       |  |  | Drawn by EE                      |  |     |  |
| Filename | track-trim2.sch |  |  | Sheet 1 of 1                     |  |     |  |